

Burner Troubleshooting

Before troubleshooting a burner, please be aware of all safety hazards. Also, follow your plants lock out/tag out and PPE procedures. Please refer to the burner manufacturer manuals for additional troubleshooting information.

Before troubleshooting a burner it is first important to understand an ovens sequence of operations. These steps must happen in order and be completed before the burner can safely ignite.

Sequence consists of the following:

- ❑ An oven purge to verify no combustibles are present in the atmosphere
 - a) The oven purge cannot be initiated until all interlocks are proven
 - b) The purge is controlled by a timer and may not be cut short
- ❑ Gas pressure switches will verify gas is available to the burner and that the gas pressure is in the proper range.
- ❑ The gas control valve will drive to the firing position
- ❑ A double blocking valve will open once the previous steps have been completed
 - a) A proof of closure switch will verify the valve is closed
- ❑ The igniter will then ignite the gas inside the burner
 - a) Igniters may be a hot surface or spark igniter
 - b) The igniter will be on for a set period of time.
- ❑ A flame sensor will detect a flame when present
 - a) Common flame sensors include flame rods and UV sensors
 - b) If no flame is detected the sequence will start over from step 1.
 - c) If a flame is detected before the previous steps are complete, the oven will not light.
- ❑ Once the flame is detected the gas control valve will drive open

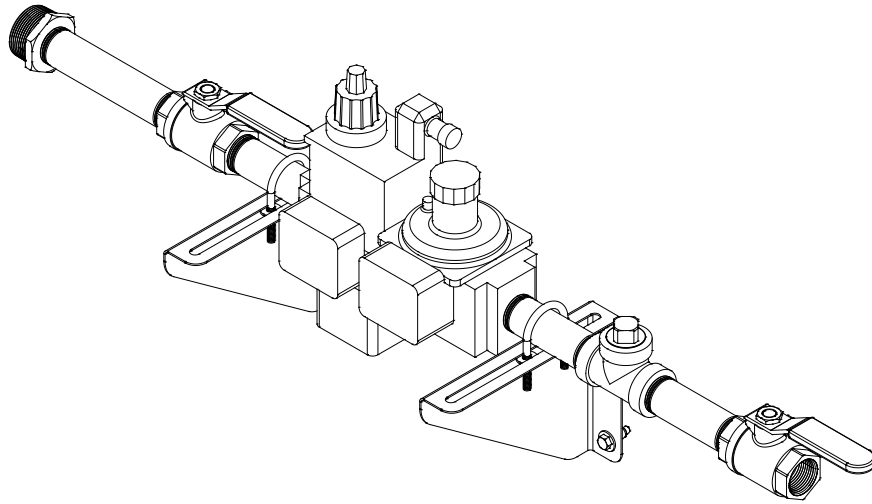

Typical LEWCO Gas Train

Symptom/ alarm	Possible Causes	Recommended Solutions
Burner Sequence does not initiate	No power to the cabinet	Verify there is power to the controller
	Operator has not started the blowers (Exhaust, Circulation, Combustion)	Start all required components
	Operator has not pressed the "Heat Enable" button	Press Heat enable
	Interlocks proven, light not illuminated	Check all interlocks
Sequence initiates but purge does not complete	Air Pressure switch has not made contact	Check air pressure switch adjustment
		Check air filter
		Check blower rotation
		Check outlet pressure form blower
	1. High gas pressure switch has activated	Check incoming gas pressure and adjust if necessary.
	2. Low gas pressure switch has activated	Check pressure switch setting and operation
	Purge cycle not completed	Check purge timer or flame safeguard system
Malfunction of the flame safeguard system	Verify there is power to the flame supervision unit.	
	Verify there is no flame on signal from the flame sensor	

Start-up sequence runs but burner does not light	No ignition:	
	Attempting to ignite at gas valve greater than 60%	Reduce start point gas flow and verify control circuit
	Weak or no spark	Verify ignition transformer is a 6000-8000 volt transformer (Not Half Wave)
		Replace the wiring to the igniter
	NO power to the ignition transformer	Restore power to the ignition transformer
	Open circuit between the ignition transformer and the igniter	Replace the wiring to the igniter
	The igniter needs cleaning	Clean the igniter
	The igniter is not correctly grounded to the burner	Clean the threads on the igniter and the burner. NOTE: do not apply grease to the threads on the igniter
Igniter insulator is broken and igniter is grounded out	Inspect the igniter and replace if necessary	
Start-up sequence runs but burner does not light <i>(Continued)</i>	Not enough Gas:	
	The gas flow into the burner is too low	Check the start-up settings and adjust low fir gas setting if necessary
		Check the regulator inlet filter
	Gas valve does not open	Check the wiring to the automatic gas shut off valve.
		Check the output from the flame safeguard
		Open manual gas cock
Check actuator wiring		
Start-up sequence runs but burner does not light <i>(Continued)</i>	No flame Signal:	
	Broken flamerod	Replace
	Bad or fluctuating ground	Verify ground
	Dirty UV scanner lens (if applicable)	Inspect and clean sensor
Flamerod grounding out (if applicable)	Verify the flamerod is installed correctly and the correct length	
The low fire flame is weak or unstable	Not enough gas	Check start up settings and adjust to increase gas flow
	Incorrect air flow setting	Check air pressure drop across the burner and adjust
The burner does	Controller not calling for increased	Verify oven temperature

not go to high fire	heat input	compared to oven setpoint
	Not enough gas pressure out of the main gas regulator	Adjust pressure regulator so pressure is increased
	Gas pressure drops as input is increased	Check for clogging of valves and regulators in gas line. Clean strainers
	Main gas control valve is not functioning	Check actuator and linkage
Burner does not achieve capacity	Main gas control valve is not functioning	Check actuator and linkage
	Burner is firing below rated input	Check gas pressure differential, adjust main gas pressure regulator as necessary
	Burner gas holes are plugged	Inspect gas holes for dirt or lint as needed
Main flame is uneven along the length of the burner	Air pressure drop/velocity is too low	Increase air pressure drop
	Poor air distribution in duct	Check profiling and duct obstructions
Main flame is yellow and long at high fire	Gas pressure too high at burner inlet	Check gas pressure against design. Adjust main gas pressure regulator.
	Air pressure drop/velocity is too low	Open air damper on combustion air blower
	Blower running in the wrong direction	Check all rotation
	Incorrect oven pressure	Check makeup air filter and clean if necessary

For any issues outside the scope of this document please contact LEWCO at (419) 502-2780, or via email at ovensales@lewcoinc.com for further assistance.