

END SIDE DRIVE

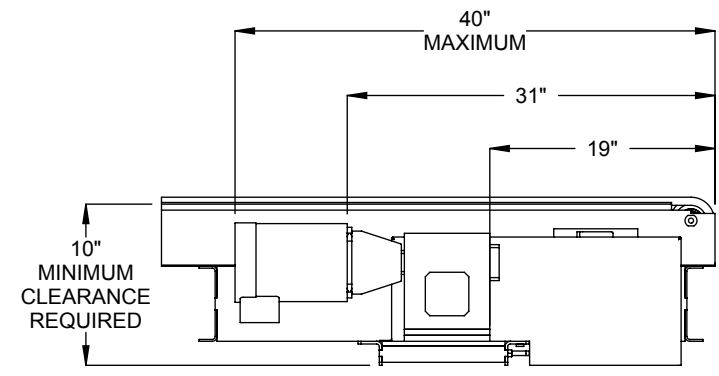

END SIDE DRIVE
END VIEW

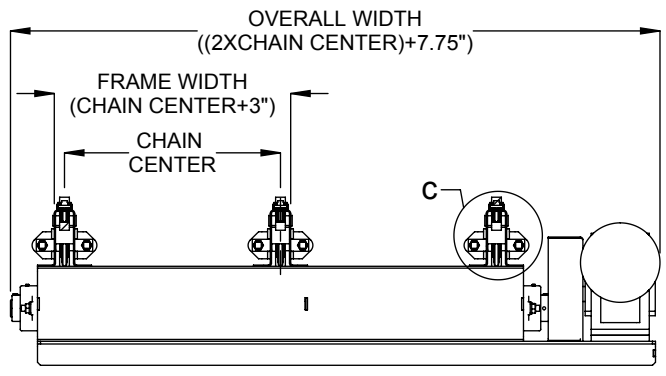

SECTION A-A

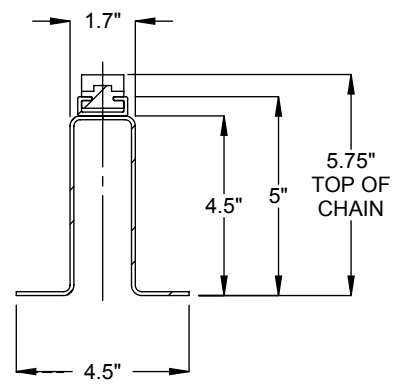

DETAIL C

SPECIFICATIONS

CHAIN CENTERS : 15" - 60"	STRANDS NUMBER : 2, 3, 4
BEGINNING ELEVATION : 12" - 60"	LENGTH : 48" - 600"
ENDING ELEVATION : 12" - 60"	SPEED : 10 - 60 FPM
DRIVE: Standard drive is an End Side Drive. <u>Optional</u> drive is an End Drive, Between Strands.	
MOTOR: 3/4 HP through 2 HP. Energy efficient and inverter duty motors also available. Voltages include 120/1/60, 230/3/60, 460/3/60 and 575/3/60 & DC Voltage.	
ROLLER CHAIN : Standard C60 chain guided by UHMW or steel track.	
SUPPORT CENTERS: Standard supports are floor supports on 5' centers,	
FRAME FINISH: Standard finish is OSHA safety blue powder. <u>Optional</u> colors include green, beige, gray, orange, black and yellow.	

Model: MSCC - Multi Strand Chain Conveyor

REV	
0	

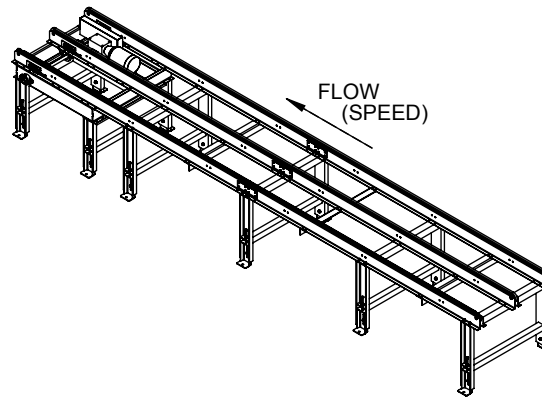

END DRIVE, BETWEEN STRANDS

HP	LOAD CAPACITY @ 60 FPM (LBS) 20 FT LENGTH CONVEYOR
3/4	1200
1	1650
1 1/2	2550
2	3500
HP	LOAD CAPACITY @ 30 FPM (LBS) 20 FT LENGTH CONVEYOR
3/4	2600
1	3500
1 1/2	5300
2	7100

MAXIMUM UNIT LOAD PER PALLET IS 3000 LBS - NOT TO EXCEED CAPACITY ABOVE.

* HP requirements will vary for different conveyor lengths, chain track material and chain lubrication condition. Consult factory.

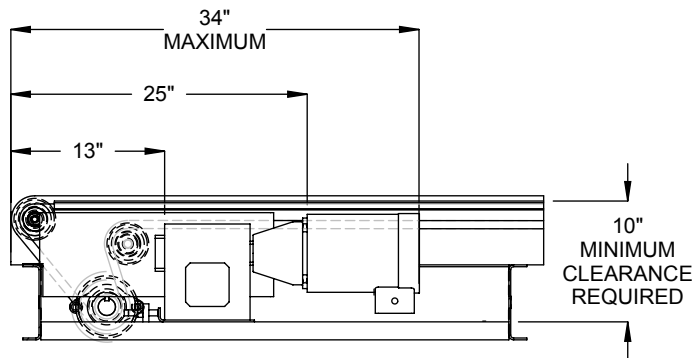

SECTION B-B
END DRIVE, BETWEEN STRANDS
END VIEW

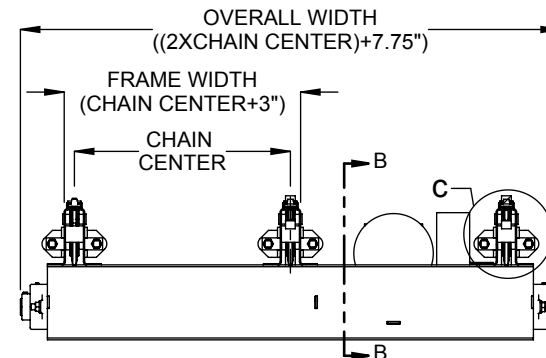

END DRIVE, BETWEEN STRANDS

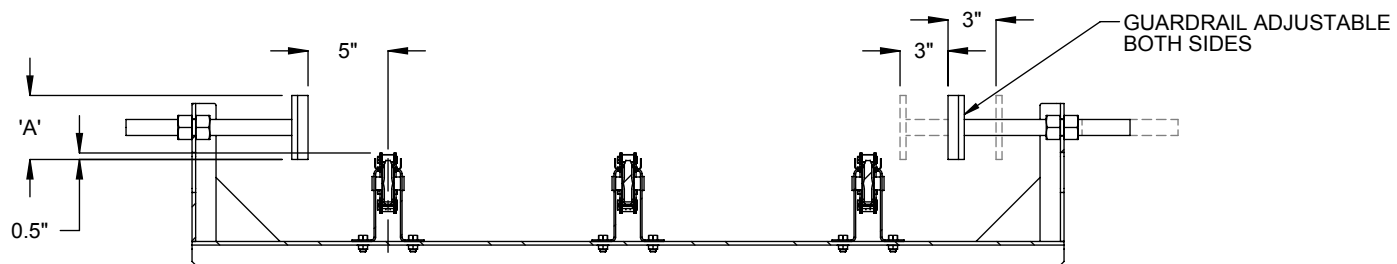

3/8" BOLT ON FLAT
GUARDRAIL OPTION