

**RAISED POSITION**

CHAINS RAISE 2 3/4" ABOVE ROLLER SURFACE IN RAISED POSITION, 1/2" BELOW ROLLERS WHEN RETRACTED.

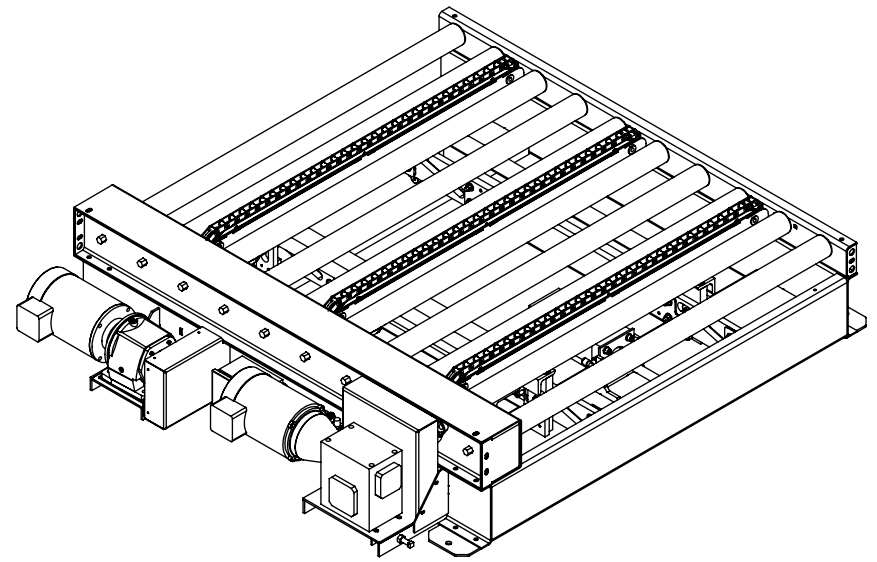

### SPECIFICATIONS

<b>EFFECTIVE WIDTH (EW):</b> 31" to 61"	
<b>ELEVATION:</b> 16" top of roller minimum	<b>LENGTH(LG) :</b> 60" to 120"
<b>NUMBER OF STRANDS (NS):</b> 2, 3 or 4	<b>SPEED:</b> 30 - 60 Feet Per Minute
<b>ROLLER CENTERS (RC):</b> 4", 6"	<b>CHAIN CENTERS (TC):</b> 12" to 48"
<b>MOTOR:</b> 3/4 HP through 1 HP. Energy efficient and inverter duty motors also available. Voltages include 120/1/60, 230/3/60, 460/3/60, 575/3/60 & DC Voltage.	
<b>ROLLER BEARING:</b> Precision ABEC style with 11/16" hexagon axle	
<b>CHAIN:</b> #C60, single pitch flat top conveyor chain, 3/4" pitch	
<b>AIR REQUIREMENTS:</b> Transfer lift is pneumatically actuated, requires approximately 0.20 Ft <sup>3</sup> of 60 PSI air per lift cycle. Includes FLR unit and (2) position double solenoid valve, 120 volt AC or 24 volt DC coils.	
<b>ELECTRICAL REQUIREMENTS:</b> Includes up and down position proximity switches, 20 to 250 volt AC/DC, prewired and terminated in 6" square junction box on outside of conveyor frame. Photo-eye sensor available as option for product detection.	
<b>STOP:</b> Fixed or retractable product stops available as an option	
<b>ROLLER COVER:</b> Standard roller finish is carbon steel. Options for galvanized steel, urethane covers, or Ultrex accumulation sleeves also available	
<b>SUPPORTS:</b> Minimum top of roller elevation is 16", supports available for up to 48" elevation	
<b>FRAME FINISH:</b> Standard finish is OSHA safety blue. Optional colors include green, beige, gray, orange, black and yellow	

**Model:** T07C25 - Internal Chain Transfer, Extended Lift, 1500 pound capacity  
 T09C25 - Internal Chain Transfer, Extended Lift, 4000 pound capacity

REV

0

