

DRIVE MOUNTED HIGH

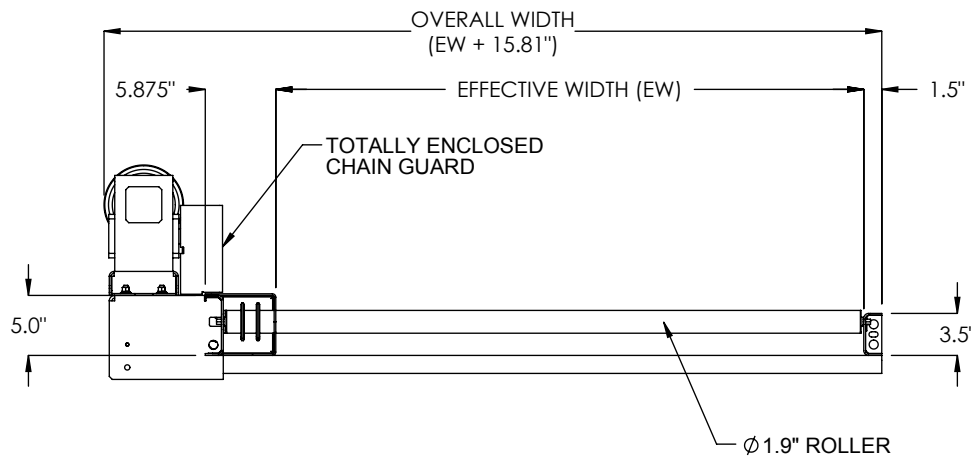

**SECTION A-A
DRIVE MOUNTED HIGH**

SPECIFICATIONS

EFFECTIVE WIDTH: 6.5" - 60"

BEGINNING ELEVATION: 6.5" - 60"

DEGREES: 45°, 90°, 180°

ENDING ELEVATION: 6.5" - 60"

SPEED: 10 - 100 FPM

DRIVE: Standard drive is mounted high near center of conveyor length on chain box side. Optional drives include drive mounted low or drive mounted below and within, near center.

FRAME: Standard frame includes 5" channel on chain box side and 3-1/2" channel on opposite side with roller set high in frame. Optional frame options include 5" channel on opposite side with roller set low in frame, or structural 5@6.7# both sides with roller set low.

MOTOR: 1/2 HP through 2 HP. Energy efficient and inverter duty motors also available. Voltages include 120/1/60, 230/3/60, 460/3/60 and 575/3/60 & DC Voltage.

ROLLER BEARING: Precision, grease packed bearings, 7/16" hexagon axles.

ROLLER COVERS: Optional roller covers include galvanized roller tube, polyurethane roller sleeves, Ultrex accumulation sleeves.

SUPPORT CENTERS: Standard supports are floor supports on 10' center.

FRAME FINISH: Standard finish is OSHA safety blue powder. Optional colors include green, beige, gray, orange, black and yellow.

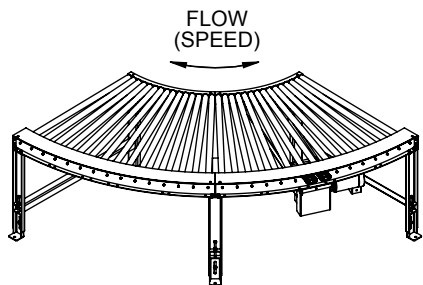

DRIVE MOUNTED BELOW AND WITHIN

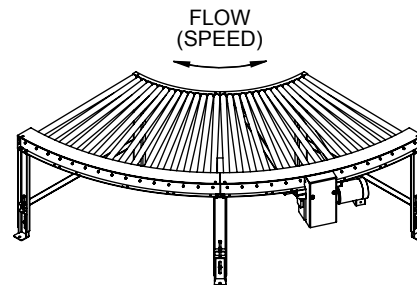

DRIVE MOUNTED LOW

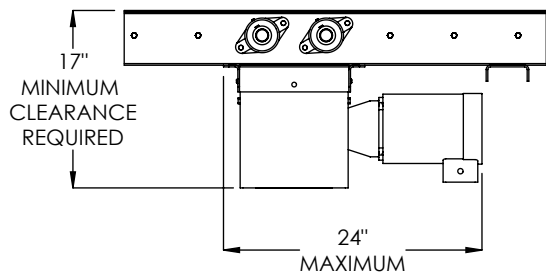

DRIVE OPTION MOUNTED BELOW AND WITHIN

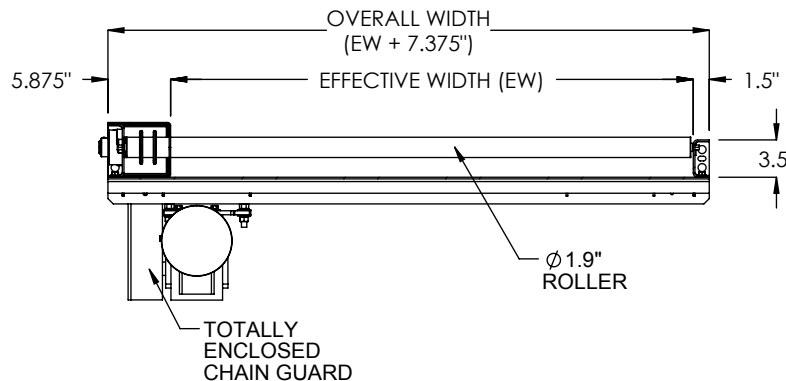

DRIVE MOUNTED BELOW AND WITHIN END VIEW

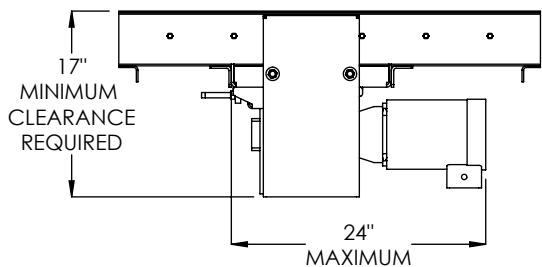

DRIVE OPTION MOUNTED LOW

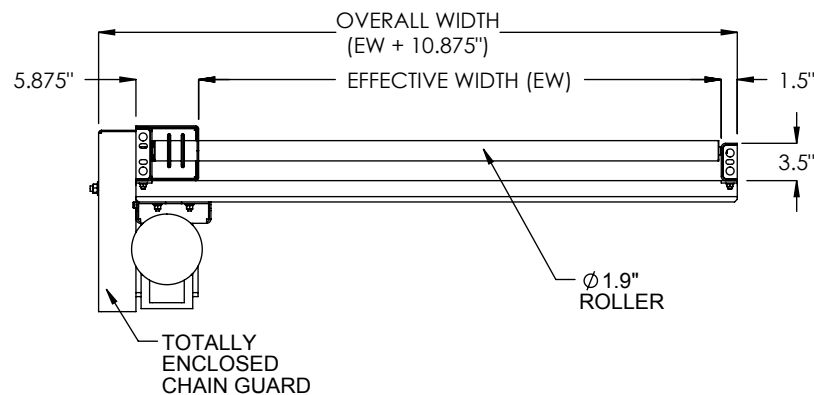

DRIVE MOUNTED LOW END VIEW

FRAME OPTIONS:

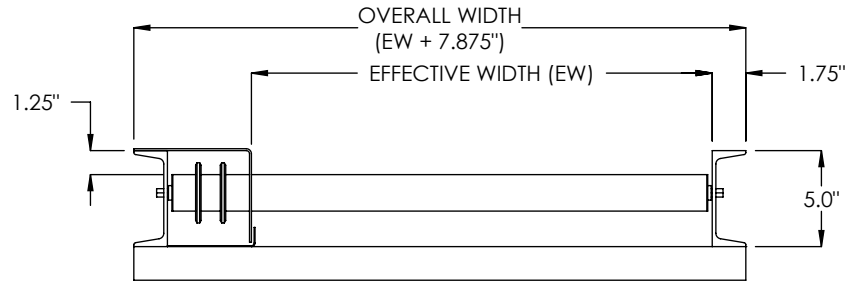

F12 CHANNEL, 5@6.7#

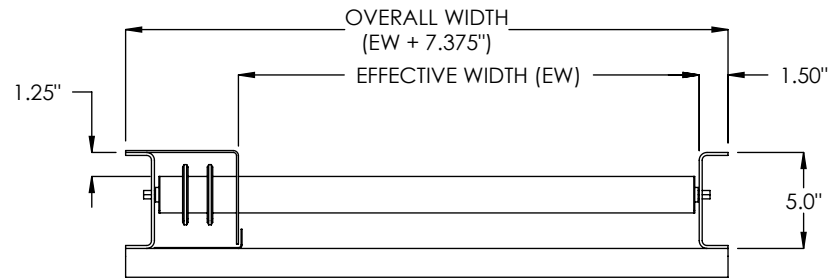

F24CHANNEL, 5" x 1-1/2" x 8ga