

CENTER DRIVE, LEFT HAND SHAFT SHOWN. RIGHT HAND SHAFT IS OPTIONAL.

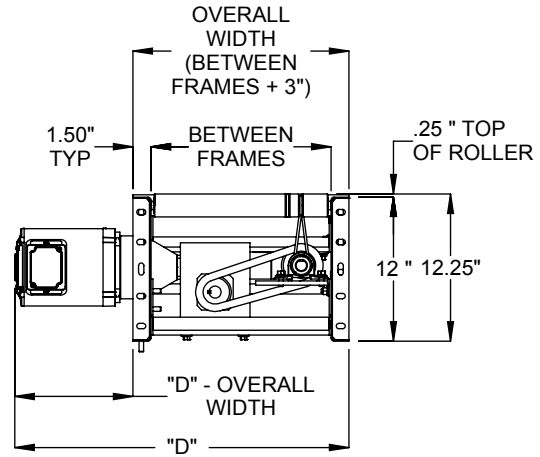

HP	"D" MAX.
1/3, 1/2, 3/4, 1	28"
1 1/2	31"
2	34 1/2"

SECTION A-A DRIVE

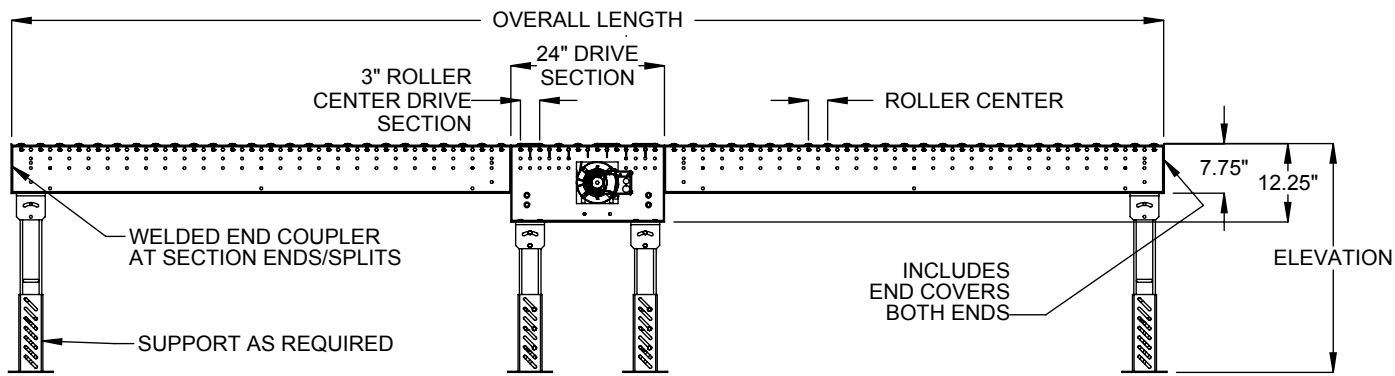
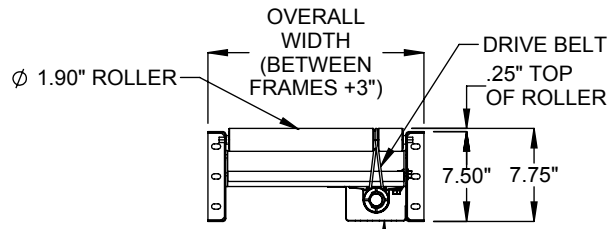

SECTION C-C INTERMEDIATE CROSS-SECTION

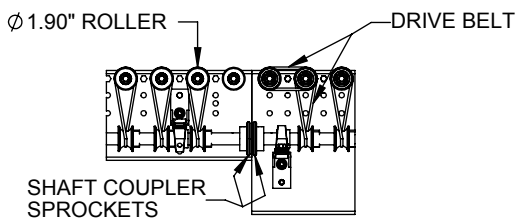

SECTION B-B COUPLED LINE SHAFT (GUARD NOT SHOWN)

SPECIFICATIONS	
BETWEEN FRAMES: 13" - 39"	
BEGINNING ELEVATION: 12.25" - 126"	LENGTH: 24" - 1200"
ENDING ELEVATION: Same as beginning elevation. Consult factory for incline/decline applications.	
ROLLER: 1.9" diameter, 16ga tube with 7/16" hex, cold rolled steel axle, spring retained with precision ABEC1 bearings.	
ROLLER CENTERS: 3", 4.5", 6"	CONVEYOR SPEED: 20 - 180 FPM
DRIVE BELT: <u>Standard</u> belt is 83A, 15lb. capacity per roller. 75lb unit load. <u>Optional</u> high tension belt is 85A, 25 lb. capacity per roller. Consult Factory for all high tension applications.	
DRIVE: <u>Standard</u> drive is center chain drive, left hand shaft. Timing belt required for 120 FPM and over. <u>Optional</u> drive is center chain drive, right hand shaft.	
MOTOR: 1/2 HP through 2 HP. Energy efficient and inverter duty motors also available. Voltages include 120/1/60, 230/3/60, 460/3/60 and 575/3/60 & DC Voltage.	
ROLLER COVERS: <u>Standard</u> galvanized roller. <u>Optional</u> polyurethane sleeves available.	
FRAME: Drive frame 12.0" x 1.5" x 12 ga. Conveyor frame 7.5" x 1.50" x 12 ga. Both frames standard with bolt-in cross members, and welded end couplers.	
SUPPORT CENTERS: <u>Standard</u> supports are floor supports on 10' centers. <u>Optional</u> supports on 5' centers. Ceiling supports are also available.	
FRAME FINISH: <u>Standard</u> finish is OSHA safety blue powder. <u>Optional</u> colors include green, beige, gray, orange, black and yellow.	

ALL PRODUCT, PRODUCT SPECIFICATIONS AND DATA ARE SUBJECT TO CHANGE WITHOUT NOTICE TO IMPROVE RELIABILITY, FUNCTION OR DESIGN OR OTHERWISE.

Model: LSLR19 - Line Shaft Straight Conveyor