

LINE SHAFT IS ALWAYS ON THE INSIDE RADIUS CURVE SIDE

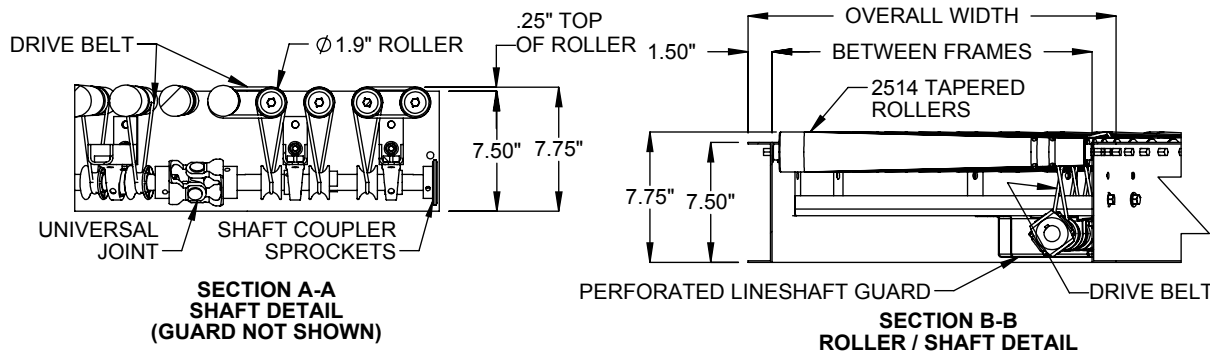
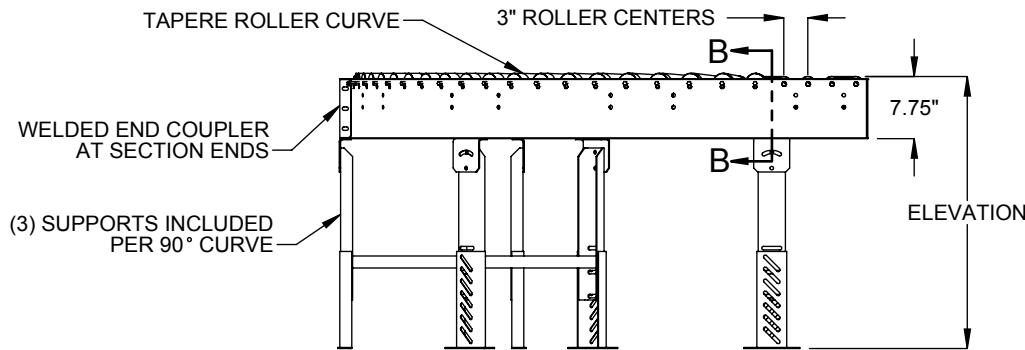

SPECIFICATIONS	
BETWEEN FRAMES: 13" - 39" See chart on sht 2 for details.	
BEGINNING ELEVATION: 12.25" - 126"	DEGREES: 30°, 45°, 60°, 90°, 180°
ENDING ELEVATION: Same as beginning elevation. Consult factory for incline/decline operations.	
ROLLER: 1.9" diameter, 16ga tube with 7/16" hex, cold rolled steel axle, spring retained with precision ABEC1 bearings.	
ROLLER CENTERS: Nominal 3"	CONVEYOR SPEED: 20 - 180 FPM
DRIVE BELT: <u>Standard</u> belt is 83A, 15 lb. capacity per roller. <u>Optional</u> high tension belt is 85A, 25 lb. capacity per roller. Consult Factory for high tension applications.	
DRIVE: Driven by LSLR19.	
ROLLER COVER: <u>Standard</u> galvanized roller. <u>Optional</u> polyurethane sleeves.	
FRAME: 7.75" x 1.50" x 12 ga. Standard bolt-on cross members and welded couplers.	
SUPPORT CENTERS: <u>Standard</u> (3) supports included per 90° curve. (5) supports included per 180° curve, (2) supports included per other angle options.	
FRAME FINISH: <u>Standard</u> finish is OSHA safety blue powder. <u>Optional</u> colors include green, beige, gray, orange, black and yellow.	

ALL PRODUCT, PRODUCT SPECIFICATIONS AND DATA ARE SUBJECT TO CHANGE WITHOUT NOTICE TO IMPROVE RELIABILITY, FUNCTION OR DESIGN OR OTHERWISE.

Model: LSTRC19 - Line Shaft Tapered Roller Curve

ARRANGEMENT SPECIFICATIONS					
BETWEEN FRAMES	OVERALL WIDTH	TOTAL NUMBER OF ROLLERS			
		180°	90°	45°	30°
13"	16"	40 TAPERED 8 STRAIGHT	20 TAPERED 8 STRAIGHT	10 TAPERED 8 STRAIGHT	6 TAPERED 8 STRAIGHT
15"	18"				
17"	20"				
19"	22"				
21"	24"				
23"	26"				
25"	27"				
27"	30"	60 TAPERED 8 STRAIGHT	30 TAPERED 8 STRAIGHT	14 TAPERED 8 STRAIGHT	8 TAPERED 8 STRAIGHT
31"	34"				
33"	36"				
37"	40"				
39"	42"				