

## Adjustable Supports ~ Assembly & Adjustment

Copyright© 2012 LEWCO, Inc.

Effective: February 2012

Rev.0

### Safety Considerations

#### Maintenance & Troubleshooting

- Only experienced and trained personnel should perform maintenance, including adjustments.
- Turn OFF and lockout the main power switches to the conveyor, following lockout/tagout procedures.
- Do not perform any work on the conveyor while it is running unless the nature of the maintenance absolutely requires operation of the conveyor. If the conveyor must be operated to perform maintenance procedures, allow only experienced conveyor maintenance personnel to do the work.

#### Before Re-Starting the Conveyor

- Inspect the conveyor and make certain all safety devices and guards are in place.
- Make sure all tools and/or maintenance equipment have been removed from the conveyor area.
- Make sure no material is caught or lodged in the movable parts of the conveyor.
- Make sure all personnel are clear of the conveyor and are alerted that the conveyor is about to be started.
- Allow only authorized personnel to start the conveyor following maintenance or any emergency shut-off.

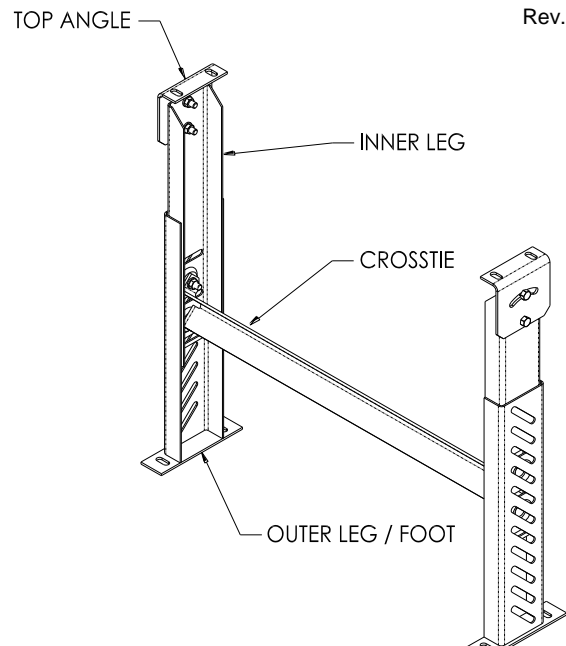

Figure 1 – Support Components

### Support Installation & Adjustment

- Bolts for attaching the supports to the bed sections are shipped in a bag attached to the supports or in a separate box.
- Set the support height. Subtract frame height from desired conveying surface. See Figure 2. Adjust the supports to this dimension by sliding inner and outer legs and tighten all butt couplings and support mounting bolts.
- Adjust crosstie locations, evenly spacing them over the height of the support.
- Supports should be located at the ends of the conveyor and centered under each splice on multi-piece conveyors (nominal 10' centers).
- If supports are located on nominal 5' centers, center additional supports midway between supports at splices.
- Check that conveyor is level across both width and length of conveyor. Adjust supports if necessary.
- Ensure that both dimensions are the same. Adjust or shim supports as required. Both sides of the conveyor must be in the same plane (bed not twisted).
  - Tighten all butt couplings and support mounting bolts and lag supports to floor.

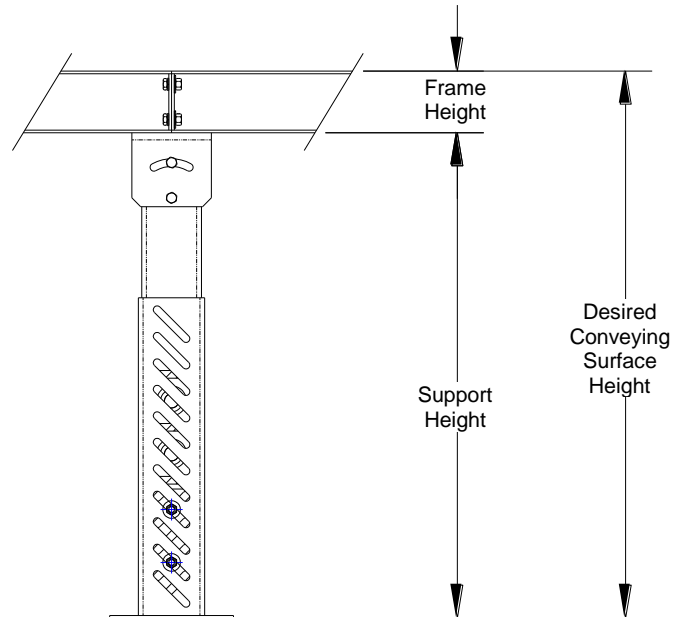

Figure 2 – Support Height Adjustment

## Warranty

**NOTE: This warranty supersedes all previous editions.**

**Seller's warranty as stated herein shall be effective only upon payment in full by the Buyer for the affected goods and/or services.**

Every LEWCO, Inc. product has been carefully inspected before shipment and we guarantee to correct any defect caused by faulty material or workmanship. Seller's obligation under this warranty is for one year or 4000 hours of use, whichever comes first, after shipment of products or equipment. The Seller warrants that the equipment furnished and the material used in its manufacturing shall be of good quality and free from defects. Subject to the conditions stated herein, the Seller will replace (F.O.B. Sandusky, OH) or repair any equipment proving defective in material or workmanship. Defect(s) to be verified by Seller's inspection upon receiving products or equipment at Seller's plant. Cost for shipping of defective and/or replacement parts to be incurred by Buyer. Credit for return shipping charges may be issued to the Buyer after any and all inspections are concluded. Failure due to abuse, overloading, maintenance neglect, exposure to corrosive or abrasive materials, or improper use shall not be subject to said warranty. Any modification to equipment or systems without Seller's written consent voids this warranty. Component parts not of Seller's manufacture (such as motors, fans and reducers) will be covered by the original manufacturer's warranty and not by Seller. In the case of failure during the warranty period, contact your Seller's representative or the nearest authorized service representative of the manufacturer. Standard warranty does not include labor to remove and/or install defective equipment. If a Seller's Representative is required for additional assistance, contact our Customer Service Department. Labor will be charged at a prevailing rate, plus travel expenses. Seller shall not be liable for loss of profits, delays or expenses incurred by failure of said parts, whether incidental or consequential. Except as stated herein, the Seller makes no other warranties, expressed or implied, including warranties of merchantability and fitness for a particular purpose. There are no warranties, which extend beyond the description on the face thereof. Buyer's exclusive remedy for claims arising hereunder shall be for damages. The Seller's alleged liability for defective products or equipment, irrespective of whether such defects are discoverable or latent, shall in no event exceed the cost to the Seller of repairing, at the Seller's option, the defective or damaged products or equipment. In no event, including in the cost of a claim of negligence, shall the Seller be liable for incidental or consequential damage. The Seller makes no warranties or representations, express or implied, with respect to the product or any service, advice or consultation, if any, furnished to the Buyer by any other party, by the Seller or its representatives. Seller shall not be liable for any loss, personal injury or property damage directly or indirectly arising from the use of its product, advice or service, or for incidental, consequential or punitive damages of any description, whether any such claim be based on warranty, contract, negligence, strict liability or other tort, or otherwise. No deviation from these standard Terms and Conditions of Warranty will be recognized or allowed unless prior written authorization is obtained by Buyer, from Seller.