

DRIVE MOUNTED HIGH

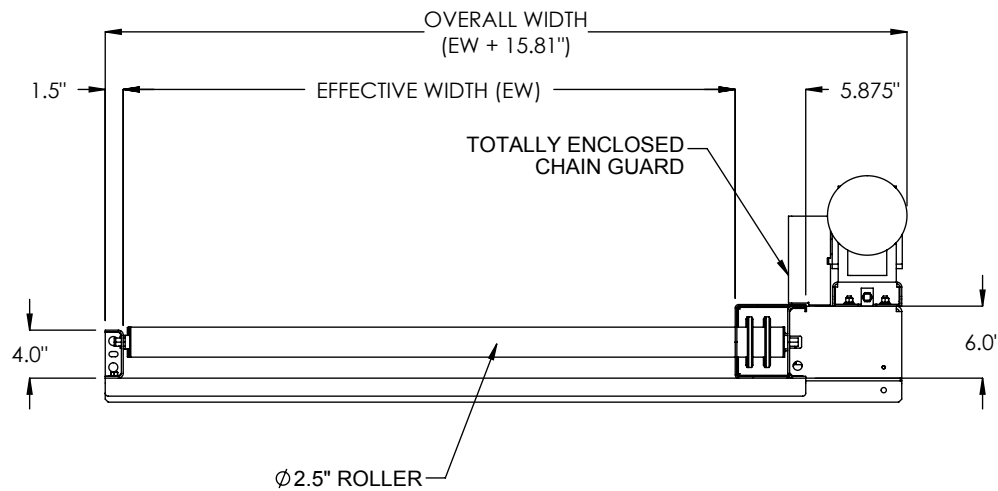

**SECTION A-A
DRIVE MOUNTED HIGH**

SPECIFICATIONS

EFFECTIVE WIDTH: 6" - 60"	
BEGINNING ELEVATION: 7" - 120"	LENGTH: 48" - 900"
ENDING ELEVATION: 7" - 120"	SPEED: 10 - 150 FPM
ROLLER CENTERS: 4.5", 6", 9", 12"	
ROLLERS: CDLR25 Roller - 2.50" diameter, 11ga wall tube. CDLR26 Roller - 2.625" diameter, 7ga wall tube. All rollers with 11/16" hex cold rolled steel axles, spring retained. Standard bearings are precision, grease packed bearings.	
DRIVE: Standard drive is mounted high near center of conveyor length on chain box side. <u>Optional</u> drives include drive mounted low or drive mounted below and within, near center.	
FRAME: Standard frame includes 6" channel on chain box side and 4" channel on opposite side with roller set high in frame. <u>Optional</u> frame options include 6" channel on opposite side with roller set low in the frame, or structural 6@8.2# & 4@5.4# with rollers set high, or structural 6@8.2# both sides with roller set low.	
MOTOR: 1/2 HP through 2 HP. Energy efficient and inverter duty motors also available. Voltages include 120/1/60, 230/3/60, 460/3/60 and 575/3/60 & DC Voltage.	
ROLLER COVERS: <u>Standard</u> roller surface is carbon steel. <u>Optional</u> roller covers for 2.5" rollers includes galvanized roller tube, polyurethane roller sleeves, Ultrax accumulation sleeves.	
SUPPORT CENTERS: <u>Standard</u> supports are floor supports on 5' center.	
FRAME FINISH: Standard finish is OSHA safety blue powder. <u>Optional</u> colors include green, beige, gray, orange, black and yellow.	

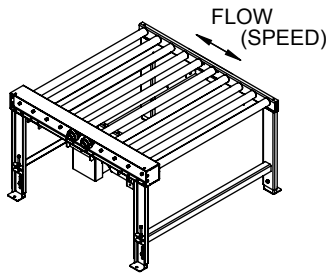

DRIVE MOUNTED BELOW AND WITHIN

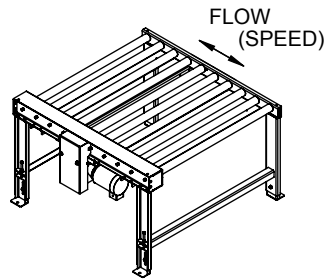

DRIVE MOUNTED LOW

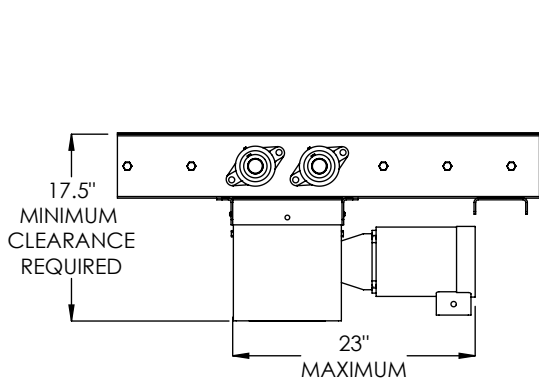

DRIVE OPTION MOUNTED BELOW AND WITHIN

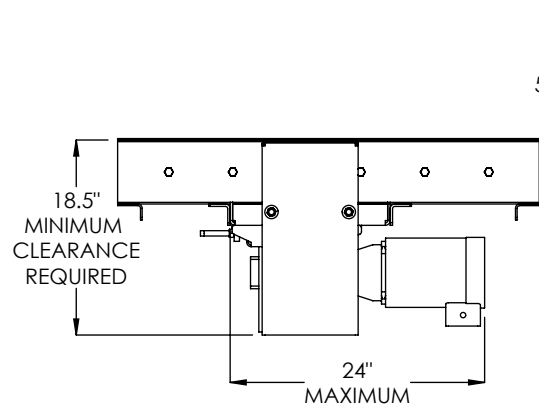

DRIVE OPTION MOUNTED LOW

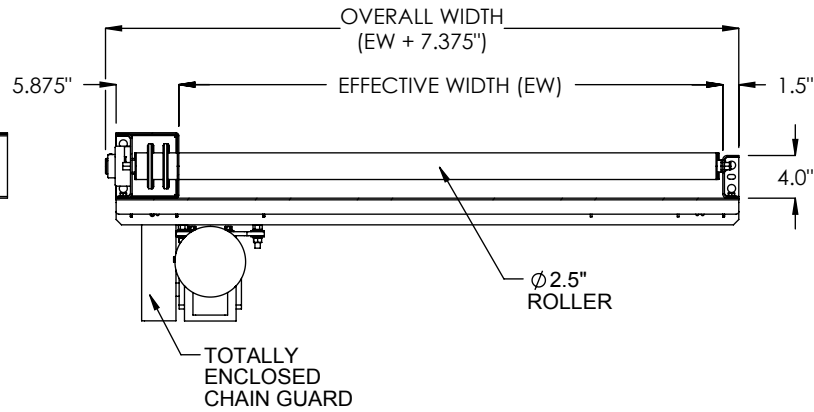

DRIVE MOUNTED BELOW AND WITHIN END VIEW

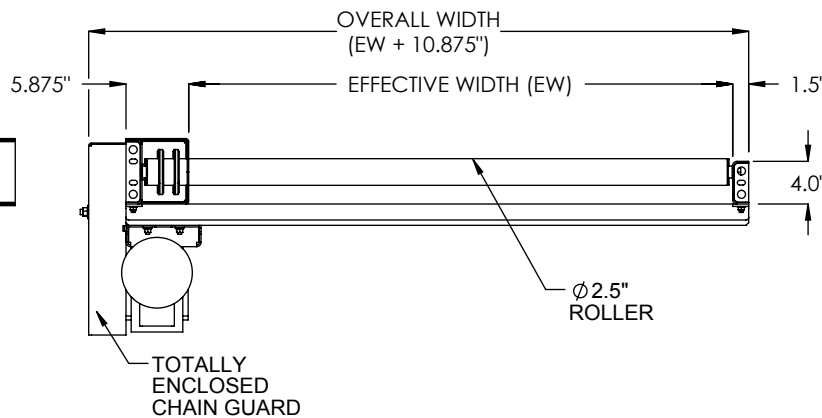

DRIVE MOUNTED LOW END VIEW

**LOAD CAPACITY @ 60 FPM (LBS)
CENTER DRIVE, 6" ROLLER CENTERS, 20 FT LENGTH**

HP	WIDTH		
	12"	36"	60"
1/2	1550	1300	1050
3/4	2500	2250	2000
1	4100	3850	3600
1 1/2	6300	6050	5850
2	10300	10100	9850

**LOAD CAPACITY @ 30 FPM (LBS)
CENTER DRIVE, 6" ROLLER CENTERS, 20 FT LENGTH**

HP	WIDTH		
	12"	36"	60"
1/2	3500	3900	3650
3/4	6350	6100	5850
1	10350	10100	9850
1 1/2	15650	15450	15200
2	21000	20750	20500

RECOMMENDED MAXIMUM CONVEYOR LOAD IS 1000 LBS PER LINEAR FOOT - NOT TO EXCEED CAPACITY ABOVE. FOR HEAVIER LOADS, CONSULT FACTORY.

*** HP requirements will vary for different drive options, conveyor lengths, roller centers, pallet types and chain lubrication conditions. Consult factory.**

GUARDRAIL OPTION

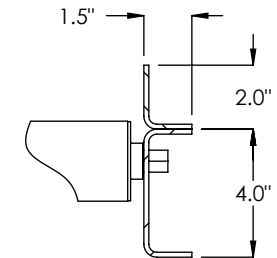

2" x 1-1/2" x 8ga BOLT ON CHANNEL

FRAME OPTIONS:

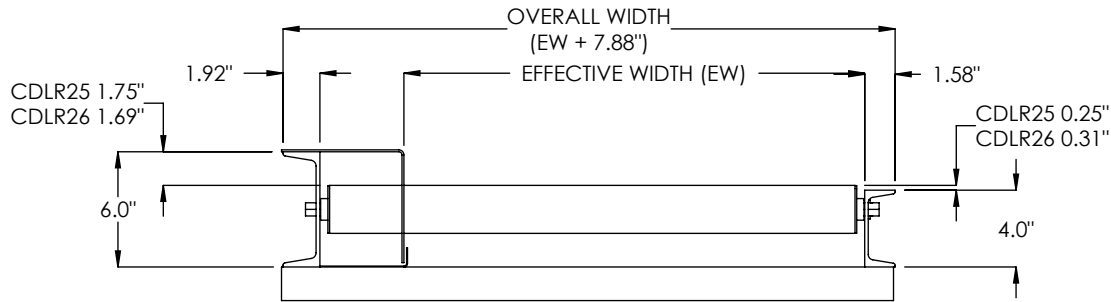

F08 CHANNEL, 6@8.2# & 4@5.4#

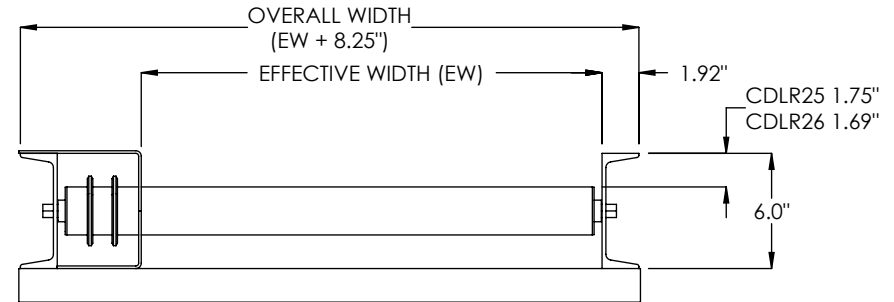

F17 CHANNEL, 6@8.2#

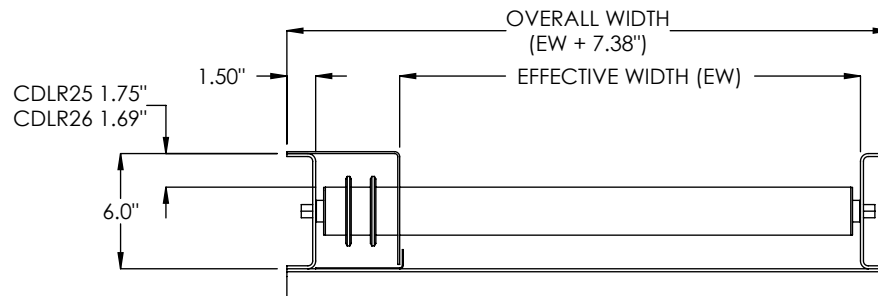

F22 CHANNEL, 6" x 1-1/2" x 8ga