

LEWCO Conveyors

by LEWCO, Inc.

Installation, Operation & Maintenance Manual

Model CDLR 19, 25, 26, 35

Effective: January, 2007

Rev: 01

Copyright© 2006 LEWCO, Inc

Table of Contents

Safety	3
Support Installation.....	5
Conveyor Set Up.....	5
Chain Installation – Multiple Section Conveyors.....	6
Pre-Startup Checks.....	6
Maintenance.....	7
Troubleshooting.....	8
Replacement Parts.....	9

Safety

Hazard Labels

- To reduce the possibility of injury to personnel operating or in the vicinity of LEWCO conveying equipment, warning signs are posted at potential hazard points on the equipment. Examine this equipment and become familiar with potential hazard areas.
- Instruct all personnel to heed these potential hazard areas.
- The following illustrations represent the typical hazard signs found at hazardous areas on LEWCO Conveyors.



Safety Considerations

Guards and Guarding

All LEWCO standard conveyor equipment is equipped with standard machine guarding methods. It is the responsibility of the owner, however, to ensure that proper guarding methods are present to comply with OSHA Standards – 29 CFR – 1910.212 Machinery and Machine Guarding. Special consideration should be given to areas where multiple pieces of equipment interface.

1910.212(a)

Machine guarding.

1910.212(a)(1)

Types of guarding. One or more methods of machine guarding shall be provided to protect the operator and other employees in the machine area from hazards such as those created by point of operation, ingoing nip points, rotating parts, flying chips and sparks. Examples of guarding methods are barrier guards, two-hand tripping devices, electronic safety devices, etc.

1910.212(a)(2)

General requirements for machine guards. Guards shall be affixed to the machine where possible and secured elsewhere if for any reason attachment to the machine is not possible. The guard shall be such that it does not offer an accident hazard in itself.

1910.212(a)(3)

Point of operation guarding.

1910.212(a)(3)(i)

Point of operation is the area on a machine where work is actually performed upon the material being processed.

1910.212(a)(3)(ii)

The point of operation of machines whose operation exposes an employee to injury, shall be guarded. The guarding device shall be in conformity with any appropriate standards thereof, or, in the absence of applicable specific standards, shall be so designed and constructed as to prevent the operator from having any part of his body in the danger zone during the operating cycle.

1910.212(a)(3)(iii)

Special handtools for placing and removing material shall be such as to permit easy handling of material without the operator placing a hand in the danger zone. Such tools shall not be in lieu of other guarding required by this section, but can only be used to supplement protection provided.

Operation & Use

- Only experienced and trained personnel should operate the conveyor.
- Personnel should be trained in operation under normal and emergency conditions.
- Personnel on or near the conveyor should be instructed as to the location and operation of stopping devices.
- Keep starting and stopping controls free from obstructions, and instruct personnel working at or near the conveyor of their locations.
- Do not wear loose clothing while operating the conveyor. Long hair and jewelry are potential hazards of entanglement.
- Watch for hazardous conditions—sharp edges and protruding parts, etc.
- Use the conveyor to transport only material it is capable of being handled safely.
- Keep area around loading and unloading points free from obstructions.
- Prohibit personnel from riding on the conveyor.
- Before turning the conveyor ON, inspect it for foreign objects that could injure personnel or damage the equipment.
- Alert personnel in the area prior to starting conveyor.
- Check belt tracking to make sure it is running straight on the conveyor.
- After startup, make sure all areas of the conveyor are operating properly.

Maintenance & Troubleshooting

- Only experienced and trained personnel should perform maintenance, including lubrication and adjustments.
- A maintenance program should be established to insure that all conveyor components are maintained in a condition which does not constitute a hazard to personnel.
- Turn OFF and lockout the main power switches to the conveyor, following lockout/tagout procedures.
- Do not perform any work on the conveyor while it is running unless the nature of the maintenance absolutely requires operation of the conveyor. If the conveyor must be operated to perform maintenance procedures, allow only experienced conveyor maintenance personnel to do the work.
- Do not wear loose clothing while performing maintenance on an operating conveyor.
- Use extreme care when using mechanical aids such as hoists, cables, and other equipment to perform maintenance. They can cause damage to the conveyor and cause a dangerous condition when the conveyor is turned on.
- Poor housekeeping practices cause accidents and inefficient conveyor operation. Keep area and conveyor clean from spilled lubricants and other materials. Make sure no material is caught or lodged in the movable parts of the conveyor unless necessary during maintenance.

Before Re-Starting the Conveyor

- Inspect the conveyor and make certain all safety devices and guards are in place.
- Make sure all tools and/or maintenance equipment have been removed from the conveyor area.
- Make sure no material is caught or lodged in the movable parts of the conveyor.
- Make sure all personnel are clear of the conveyor and are alerted that the conveyor is about to be started.
- Allow only authorized personnel to start the conveyor following maintenance or any emergency shut-off.

Support Installation

- Bolts for attaching the supports to the bed sections are shipped in a bag attached to the supports or in a separate box.
- Set the support height. Subtract frame height dimension from desired conveying surface. See Figure 2.1. Adjust the supports to this dimension by sliding inner and outer legs and tighten bolts.
- Supports should be located at ends of conveyor and centered under each splice on multi-piece conveyors (nominal 10' centers).
- If supports are located on nominal 5' centers, center additional supports midway between supports at splices.

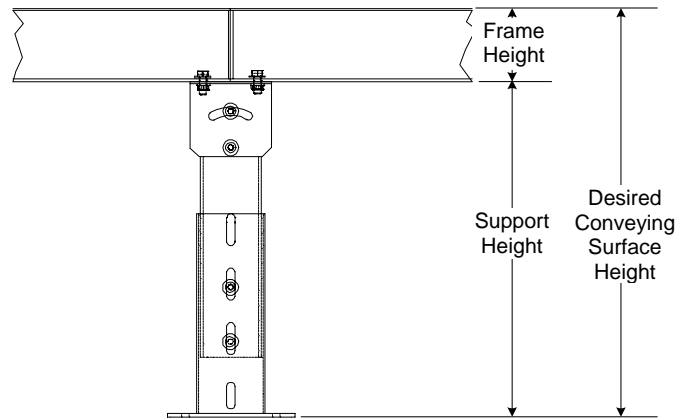

Figure 2.1 – Support Height Adjustment

Conveyor Set Up

- Mark a chalk line on floor to locate center of the conveyor.
- Place the drive section in position.
- Install remaining sections in order. Conveyor sections have a section number label, which includes the Sales Order number, Line Item number, and Section Assembly number (last two digits). Conveyors made up of more than one section are to be assembled in ascending numerical order, starting with Section Assembly 01 at the product infeed end.
- Check that conveyor is level across both width and length of conveyor. Adjust supports if necessary.
- Check all bed sections for square. See Figures 3.1 and 3.2. Use a string stretched from opposing corners at edge of bed to aid in straightening conveyor. Ensure that both dimensions are the same. Adjust or shim supports as required. Both sides of the conveyor must be in the same plane (bed not twisted).

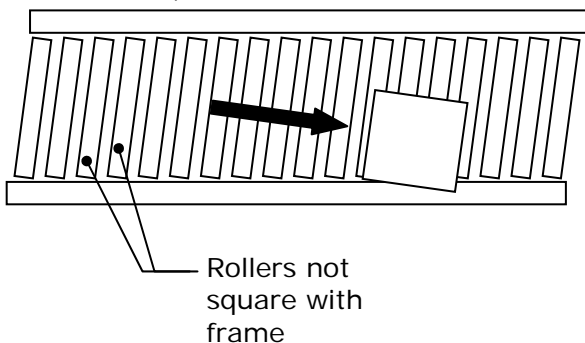

Figure 3.1 "Racked" Conveyor

- Tighten all butt couplings and support mounting bolts and lag conveyor to floor.

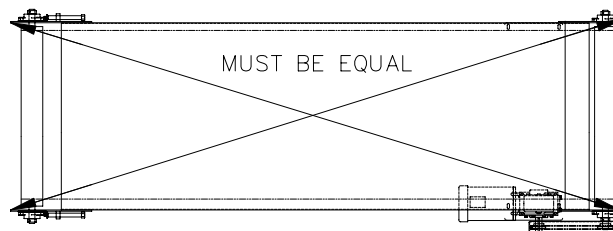

Figure 3.2 Check the bed for square

Chain Installation – Multiple Section Conveyors

- On multiple section conveyors, remove the chain box covers by removing the bolts and nuts securing the cover to the frame rail. A correct length loop of chain to connect the two sections together is supplied.
- Open the master link of this chain loop, and pass the chain around the two adjacent empty sprockets. Reinstall the master link. Note that this chain loop will have very little slack, and the use of a chain tensioning tool may be required to install the master link.
- Reinstall the chain box tops in their original locations.
- Install bolt heads on OUTSIDE of conveyor
- Prior to starting the conveyor, again ensure that all rollers and pulleys are square and level.
- Start the conveyor.

Pre-Startup Checks

- MOST speed reducers are shipped with oil, HOWEVER, DO check for proper oil level before operating the conveyor.
- CHECK FOR REDUCER VENT PLUG AND INSTALL IF NECESSARY. See Figure 5.1. To install, remove the solid plug and replace with vent plug.
- Remove drive chain guard and inspect drive chain and sprockets.
- Chain should have sag on the slack side per Figure 5.2. Measure the sag half way between the two sprockets.
- Sag should be $\frac{1}{4}$ " or 2% of the sprocket center distance.
- Inspect drive sprocket and pulley set screws. These should be tight against the reducer and pulley shafts. Using a straight edge check to assure the sprockets are aligned by placing the straight edge flush against the sprocket flanges.
- Re-install chain guard after inspection.

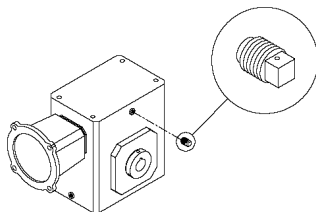

Figure 5.1 Reducer Vent Plug Installation



Figure 5.2 Drive Chain Sag

Maintenance

Effective operation and useful life of any equipment is directly related to the care and service it receives. A pre-determined maintenance schedule, including inspection, lubrication and cleaning should be established for each conveyor. Establish and maintain "Log Sheets" on each conveyor to record date and results of inspections, lubrication, and parts replacements. General inspections of all conveyors should be performed at regular intervals depending on use and service conditions.

Maintenance Intervals

The following chart gives a brief overview of what maintenance should be performed on a periodic basis.

COMPONENT	ACTION	SCHEDULE		
		WEEKLY	MONTHLY	QUARTERLY
MOTOR	Check noise.		✓	
	Check temperature.	✓		
	Check mounting bolts.		✓	
REDUCER	Check noise.		✓	
	Check temperature.		✓	
	Check oil level.			✓
DRIVE CHAIN	Check tension.			✓
	Lubricate.	✓		
	Check for wear.			
SPROCKETS	Check for wear.			✓
	Check set screws and keys.			✓
BEARINGS (Pulleys & Rollers)	Check noise.		✓	
	Check mounting bolts.			✓
STRUCTURAL	General check: Loose bolts etc. tightened.		✓	

Maintenance Procedures

Sprocket and Chain Maintenance

- Remove drive chain guard and inspect drive chain and sprockets.
- Chain should have about 2 to 3 percent sag when measured on the lower run of chain half way between the two sprockets. See "Pre Startup Checks".
- A loose chain can jump the drive sprockets and can cause sprocket wear and failure. A tight chain requires excessive motor power, and can cause chain and sprocket failure.
- Inspect drive sprocket and pulley set screws for tightness against the reducer and pulley shafts.
- Check sprocket alignment. Misalignment causes wear on one side of the sprocket. Check for a misaligned shaft or a sprocket off center.
- Check shaft bearing set screws.
- Lubricate the drive chain with SAE-30 oil approximately every 40 hours of operation. Lubricate more frequently under extreme ambient conditions. Rinse chain in solvent before lubricating.
- Re-install chain guard after inspection and maintenance.

Motor and Reducer

- Make sure the reducer is filled to the proper level with oil. Make sure breather hole is clean and the orifice is open.
- Inspect reducer for leaks.
- Use only oil recommended by the reducer manufacturer.

Rollers and Bearings

- Check all rollers and pulleys for tightness. All rollers must rotate freely. If roller does not turn freely check for dirt accumulation in bearing area and clean.
- Lubricate all flange type bearings that have grease fittings. Use a NLGI Grade 2 Lithium base grease, Shell Alvania EP2, or equal. Snub roller and return roller bearings are lubed for life.
- Listen to bearing for excessive noise. Replace as required.

Conveyor Bed and Supports

- Check conveyor frame, splices, supports, and bearings for loose or missing hardware. Replace hardware as required.

Cleaning

- Periodically remove drive chains and clean by immersing in solvent and scrubbing with a wire brush. Rinse thoroughly and relubricate. Verify proper chain tension.
- Clean chain box and keep free of all debris.

Troubleshooting

TROUBLE	CAUSE	SOLUTION
Conveyor does not start or motor stalls.	Motor overloaded	Check conveyor loading against design parameters.
	Motor drawing excessive current.	Check circuit breaker.
Excessive wear on drive chain and/or sprockets.	Lack of lubrication.	Lubricate chain.
	Sprockets out of alignment.	Align sprockets.
	Loose drive chain.	Correct chain slack (See "Pre Startup Checks").
Loud popping and/or grinding noise.	Defective bearing.	Replace bearing.
	Loose drive sprocket set screw.	Tighten sprocket set screws and check key.
	Loose drive chain.	Correct chain slack (See "Pre Startup Checks").
Motor or reducer overheating. (Note: Many motors and reducers can be hot to the touch and still be operating within normal parameters.)	Conveyor overloaded.	Check conveyor loading against design parameters.
	Low voltage to motor.	Correct voltage level as stated on motor name plate..
	Reducer lubricant level low.	Fill reducer reservoir.

Replacement Parts

How to Order

Provide the MODEL NUMBER, and SERIAL NUMBER [located on unit label], when ordering parts for your LEWCO Conveyor. There is one unit label on each section of conveyor.

To order parts please contact your local LEWCO distributor. If unable to contact your local distributor or the original distributor that supplied the equipment, please contact LEWCO, Inc. by phone at 419-625-4014, or Fax 419-625-1247. Ask for the conveyor sales parts department.

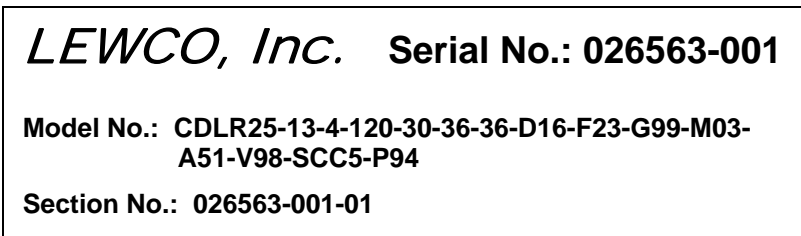

Figure 7.1 Location of Serial Number, Model Number, and Section Number on Typical Unit Label

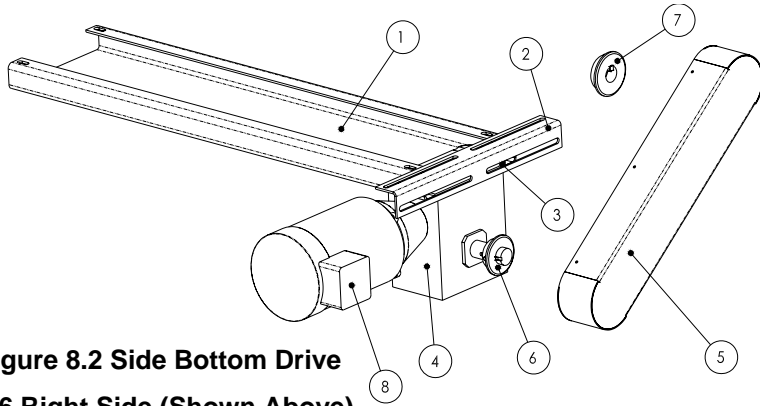

Figure 8.2 Side Bottom Drive
D16 Right Side (Shown Above)
D17 Left Side

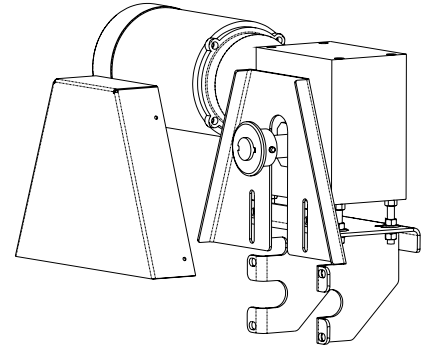

Figure 8.3 Top Drive
D13 Center (Shown Above)
D14 Left Side
D15 Right Side

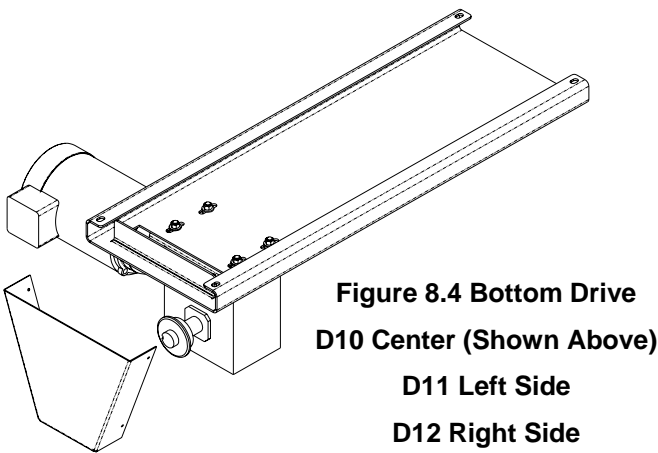

Figure 8.4 Bottom Drive
D10 Center (Shown Above)
D11 Left Side
D12 Right Side

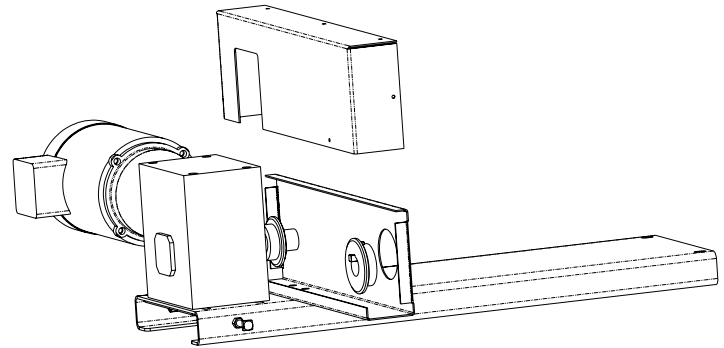

Figure 8.5 Side Top Drive
D19 Center (Shown Above)
D20 Left Side
D21 Right Side

ITEM	PART NO.	DESCRIPTION
1	CVS0171-CASE-LG	DRIVE MOUNT, CHAN WELD, GROVE, BTM MNT
2	CVP0278	GUARD MOUNTING BRKT, ANG, 8-3/8
3	CVPO264-CASE	DRIVE TENSIONER, GROVE REDUCER
4	PCP0128-30-3-56C	REDUCER, GROVE BM226, SINGLE REDTN
	PCP0128-RATIO-OS-MOUNT	REDUCER, OTHER
5	CVS0174-19	DRIVE GRD ASS'Y, NOM. 4" DIA
	CVS0174-GC	DRIVE GRD ASS'Y, OTHER
6	PCP0267-13-1.250	SPROCKET, #50 B STYLE, KWY & 2 SS
	PCP0267-TH-BORE	SPROCKET, OTHER
7	PCP0267-15-1.187	SPROCKET, #50 B STYLE, KWY & 2 SS
	PCP0267-TH-BORE	SPROCKET, OTHER
8	PCP0165	MOTOR, 1/2HP, 115/230/1/60, 56C

ABBREVIATION KEY

ABBREVIATION	DESCRIPTION
BF	BETWEEN FRAME
LG	LENGTH
BRG	BEARING
OAW	OVERALL WIDTH
SPKT	SPROCKET STYLE
TH	NO. OF TEETH
ROLCOV	ROLLER COVER
PTCH	NO. OF PITCHES
CASE	REDUCER CASE SIZE
NS	NO. OF STRANDS
RATIO	REDUCTION RATIO
OS	OUTPUT SHAFT ASSY
MOUNT	MOTOR MOUNT SIZE
TH	NO. OF TEETH
GC	GUARD CENTER TO CENTER
BORE	BORE SIZE
CC	CHAIN CENTER
BW	BELT WIDTH
RCC	ROLLER CENTER TO CENTER